

Visit us at www.injectionmolder.net

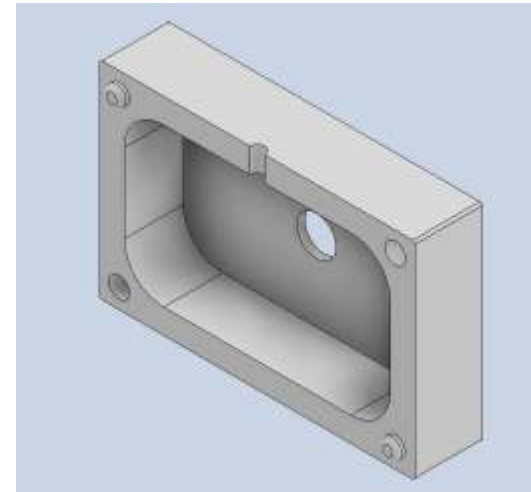

MMB-201-1
Mini-Master Mold - Cavity Specifications*

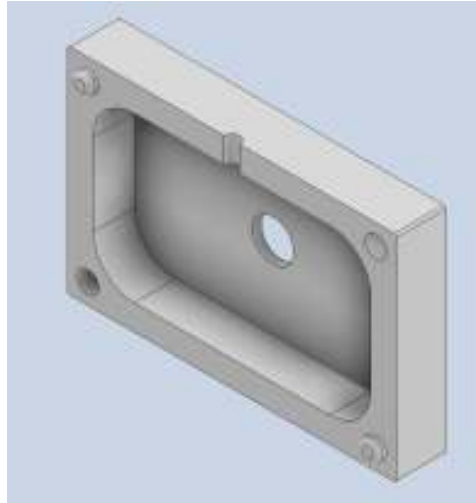
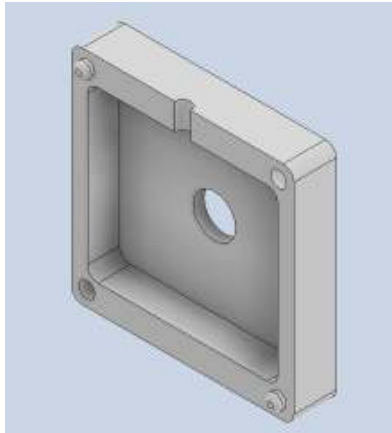
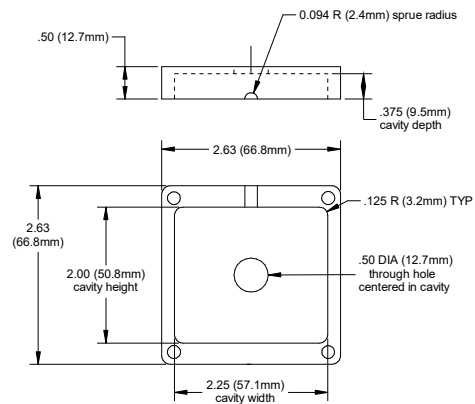

*Diagram illustrates one half of a two frame mold

MMB-301-1
Master Mold Frame-01 - Cavity Specifications*

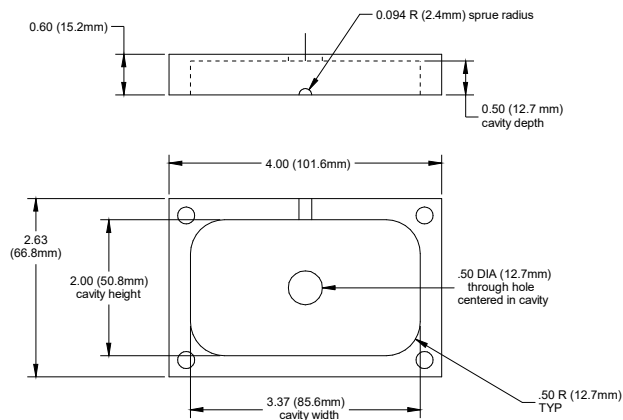

*Diagram illustrates one half of a two frame mold

MMB-401-1
Master Mold Frame-02 - Cavity Specifications*

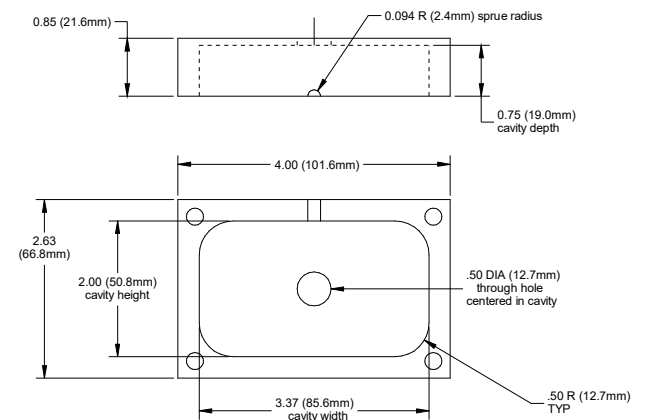

*Diagram illustrates one half of a two frame mold